

HITACHI SUMITOMO

SCX1500-2

HYDRAULIC CRAWLER CRANE

Specifications

ASIAN ISSUE



Liftcrane Working Ranges (1)

w/ 4.5m heavy-duty tapered top section:

Hook lift allowance height

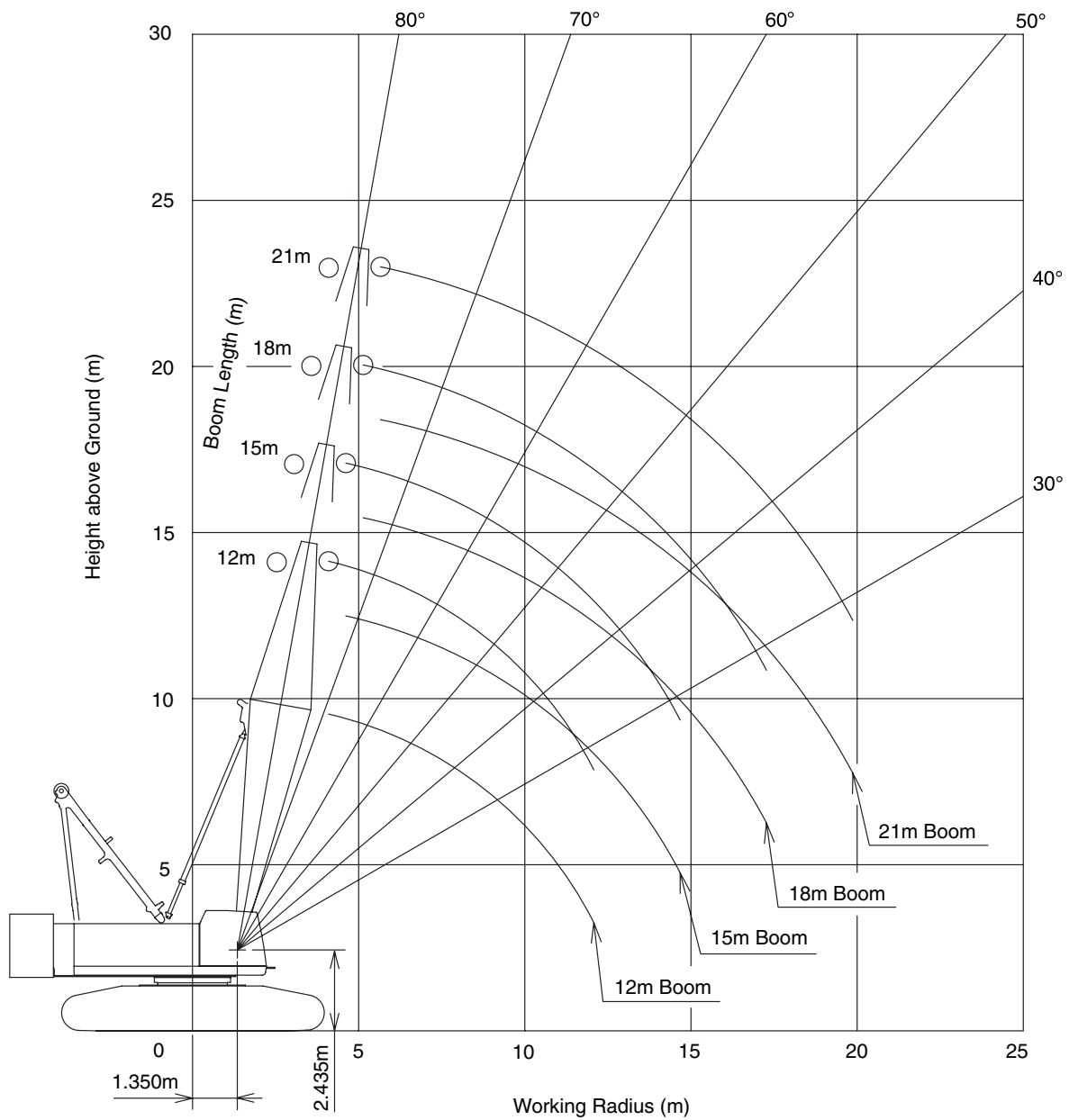
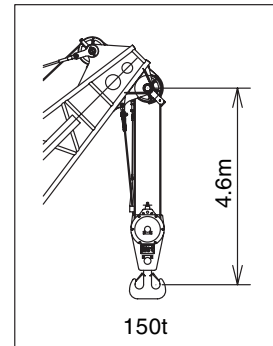

Notes :

The above diagram shows two kinds of locuses of boom peak sheave and hook points; the lower lines each indicate the locus of hook point, and these upper lines each show the locus of boom peak sheave point.

Liftcrane Capacities 150/135 metric tons

w/ 4.5m heavy-duty tapered top section:

Boom length (m) Working radius (m)	12.0	15.0	18.0	21.0
4.0	150.0/4.1			
4.5	148.1	135.0/4.7		
5.0	134.2	134.1	129.0/5.2	118.1/5.7
6.0	112.8	112.7	112.5	112.5
7.0	95.1	97.1	96.9	96.8
8.0	77.9	79.1	79.0	79.1
9.0	64.8	65.9	65.8	65.9
10.0	54.2	56.4	56.3	56.3
12.0	36.9	43.5	43.4	43.4
14.0		33.7	35.0	35.0
16.0		30.4/14.6	29.3	29.2
18.0			25.6/17.2	25.0
20.0				21.9/19.8

(EC405002)

w/ 7.5m tapered top section:

Boom length (m) Working radius (m)	15.0	18.0	21.0	24.0	27.0	30.0	33.0	36.0	39.0	42.0	45.0	48.0	51.0	54.0	57.0	60.0	63.0	66.0	69.0	72.0	75.0	
4.0	135.0/4.5																					
5.0	134.5	110.0	99.0/5.5																			
6.0	113.2	110.0	99.0	88.0/6.1	77.0/6.6																	
7.0	97.6	97.5	97.3	88.0	77.0	66.0/7.1	66.0/7.6															
8.0	79.5	79.5	79.5	79.6	77.0	66.0	66.0	55.5/8.2	55.0/8.7													
9.0	66.2	66.3	66.3	66.5	66.4	66.0	66.0	55.0	55.0	44.0/9.2	44.0/9.7											
10.0	56.9	56.8	56.8	56.9	56.8	56.8	56.7	55.0	55.0	44.0	44.0	33.0/10.2	33.0/10.8	33.0/11.3	33.0/11.8							
12.0	44.0	44.0	43.9	44.0	43.9	43.9	43.7	43.7	43.6	43.6	43.4	33.0	33.0	33.0	33.0	22.0/12.4	22.0/12.9	22.0/13.4	22.0/13.9			
14.0	33.8	35.7	35.5	35.6	35.5	35.5	35.4	35.3	35.2	35.2	35.0	33.0	33.0	33.0	33.0	22.0	22.0	22.0	22.0	19.9/14.4	17.2/15.0	
16.0	31.1/14.5	29.9	29.7	29.8	29.7	29.7	29.5	29.5	29.3	29.3	29.1	29.1	29.0	28.8	28.7	22.0	22.0	22.0	20.5	18.3	16.3	
18.0		26.3/17.1	25.5	25.5	25.4	25.4	25.2	25.1	25.0	25.0	24.8	24.8	24.7	24.5	24.4	22.0	22.0	20.9	18.6	16.6	14.7	
20.0			22.6/19.7	22.3	22.1	22.1	21.9	21.8	21.7	21.6	21.5	21.5	21.3	21.2	21.0	21.0	20.9	19.3	17.1	15.1	13.4	
22.0				19.7	19.5	19.4	19.3	19.2	19.1	19.0	18.8	18.8	18.7	18.5	18.4	18.4	18.2	17.8	15.7	13.9	12.2	
24.0				19.3/22.3	17.4	17.3	17.2	17.1	16.9	16.9	16.7	16.7	16.5	16.4	16.2	16.2	16.0	15.9	14.6	12.8	11.2	
26.0					16.6/24.9	15.6	15.5	15.3	15.2	15.1	14.9	14.9	14.8	14.6	14.5	14.4	14.3	14.1	13.5	11.8	10.3	
28.0						14.5/27.5	14.0	13.8	13.7	13.6	13.5	13.4	13.3	13.1	13.0	12.9	12.8	12.6	12.5	11.0	9.5	
30.0							12.7	12.6	12.4	12.4	12.2	12.1	12.0	11.8	11.7	11.6	11.5	11.3	11.2	10.2	8.8	
32.0							12.7/30.1	11.5	11.4	11.3	11.1	11.0	10.9	10.7	10.6	10.5	10.4	10.2	10.1	9.5	8.2	
34.0								11.2/32.7	10.4	10.3	10.1	10.1	9.9	9.8	9.6	9.6	9.4	9.3	9.1	8.9	7.6	
36.0									9.9/35.3	9.5	9.3	9.3	9.1	8.9	8.8	8.7	8.6	8.4	8.3	8.1	7.0	
38.0										8.8/37.9	8.6	8.5	8.4	8.2	8.0	8.0	7.8	7.7	7.5	7.3	6.5	
40.0											7.9	7.9	7.7	7.5	7.4	7.3	7.1	7.0	6.9	6.7	6.1	
42.0											7.8/40.5	7.3	7.1	6.9	6.8	6.7	6.5	6.4	6.2	6.1	5.6	
44.0												7.0/43.1	6.6	6.4	6.2	6.2	6.0	5.9	5.7	5.5	5.2	
46.0													6.2/45.7	5.9	5.8	5.7	5.5	5.4	5.2	5.0	4.8	
48.0														5.5	5.3	5.2	5.1	4.9	4.8	4.6	4.4	
50.0														5.4/48.3	4.9	4.8	4.6	4.5	4.3	4.1	3.9	
52.0															4.8/50.9	4.5	4.3	4.1	3.9	3.7	3.5	
54.0																4.3/53.2	3.9	3.7	3.5	3.3	3.1	
56.0																	3.6/55.8	3.3	3.1	2.9	2.7	
58.0																		3.0	2.8	2.6	2.4	
60.0																		2.9/58.4	2.5	2.3	2.1	
62.0																			2.3/61.0	2.0	1.8	
64.0																				1.7/63.6		

(EC405003)

WORKING MASS & GROUND PRESSURE:

Shoe width	Mass	Pressure
965mm	129.0t	96.0kPa <0.98kg/cm²>

WORKING MASS & GROUND PRESSURE:

Shoe width	Mass	Pressure
965mm	128.0t	95.0kPa <0.97kg/cm²>

Note: Working mass shown above is with 12.0m basic boom with 4.5m heavy-duty tapered top section, 46ton counterweight, 2.0ton auxiliary weight, 9.5ton carbody weight and 150t hook block.

Note: Working mass shown above is with 15.0m basic boom with 7.5m tapered top section, 46ton counterweight, 2.0ton auxiliary weight, 9.5ton carbody weight and 135t hook block.

General Dimensions

w/ 7.5m tapered top section:

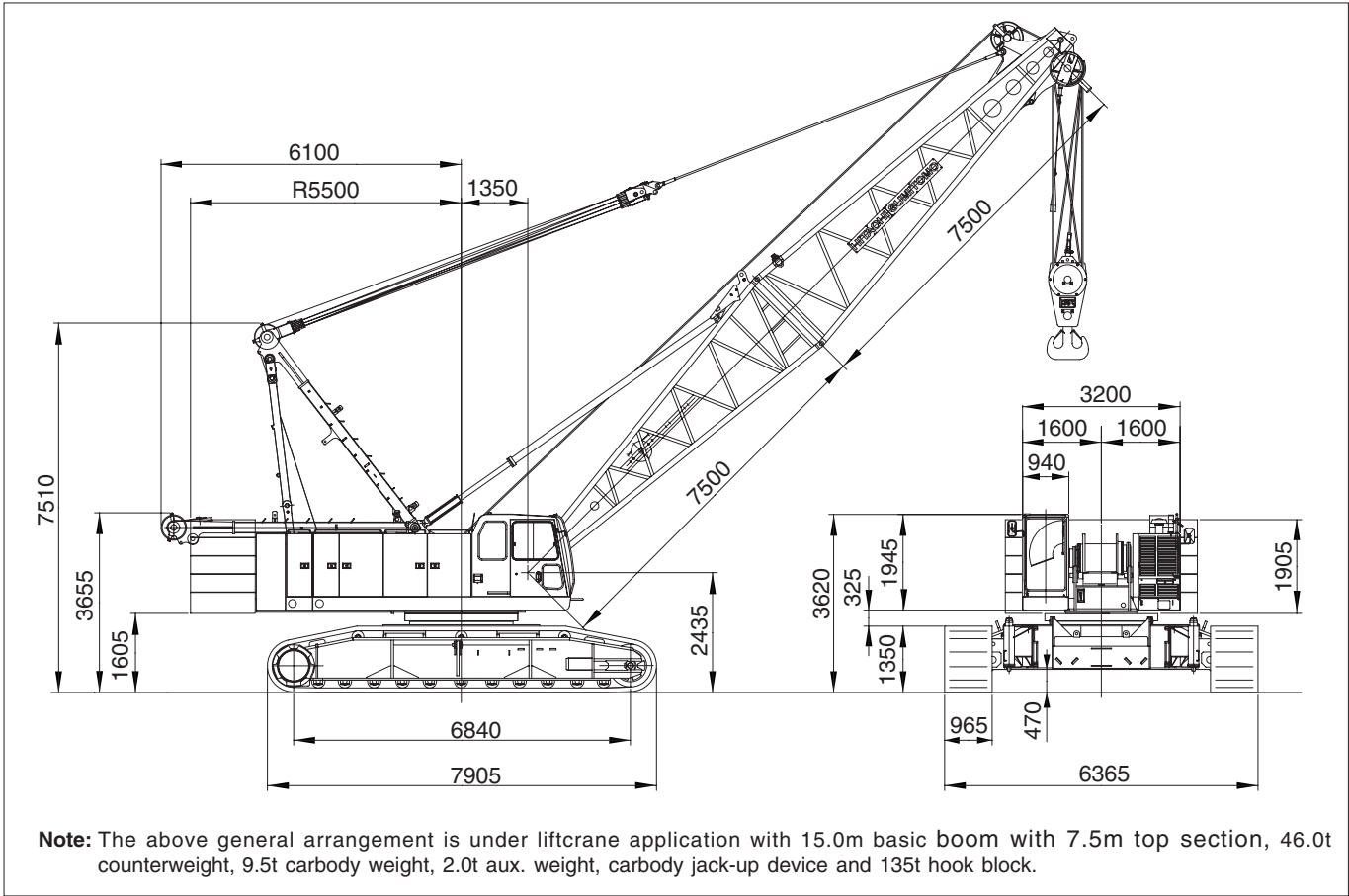

w/ 4.5m heavy-duty tapered top section:

